

KANTON GRAUBÜNDEN  
**GEMEINDE ZERNEZ**

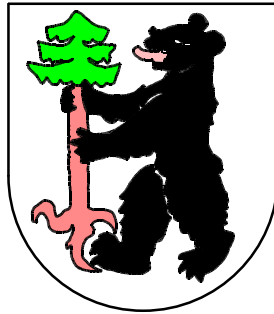

**QUARTIERPLAN  
RUZÖN**

VORPROJEKT QUARTIERSTRASSE  
TEILGEBIET RUZÖN III  
QUERPROFILE 1:100

Vom Gemeindevorstand erlassen am 28.04.2014

Der Gemeindepräsident: .....

Der Aktuar: .....

RUZÖN 190, 7530 ZERNEZ  
TEL. 081 861 24 07 , FAX 081 861 24 01  
E-MAIL: zernez@caprez-ing.ch  
MARCO MÜLLER

**CAPREZ**  
**INGENIEURE AG**



|                          |                    |           |                      |               |                            |                         |
|--------------------------|--------------------|-----------|----------------------|---------------|----------------------------|-------------------------|
| PROJEKTERT:<br>Haidegger | GEZEICHNET:<br>JAG | FREIGABE: | DATUM:<br>27.09.2013 | FORMAT:<br>A4 | FILE NAME:<br>pb000000.npl | PLAN NR.<br><b>211</b>  |
| INDEX:                   | GEZEICHNET:        | FREIGABE: | DATUM:               | ÄNDERUNG:     |                            | PROJEKT NR.<br>6.06.028 |
|                          |                    |           |                      |               |                            |                         |

# STRASSE 1

10.000

P = 1472.78

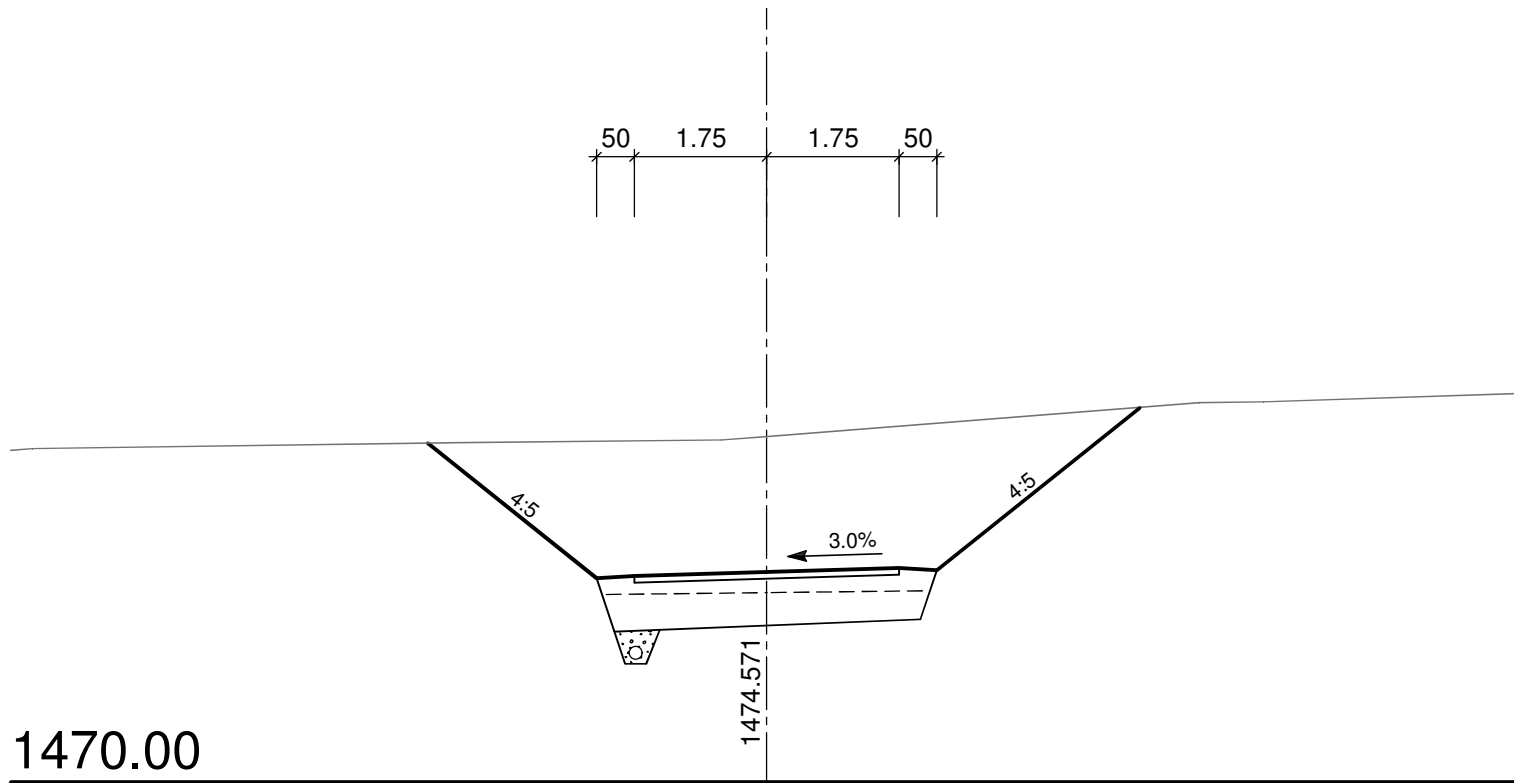

# STRASSE 1

70.000

P = 1475.77

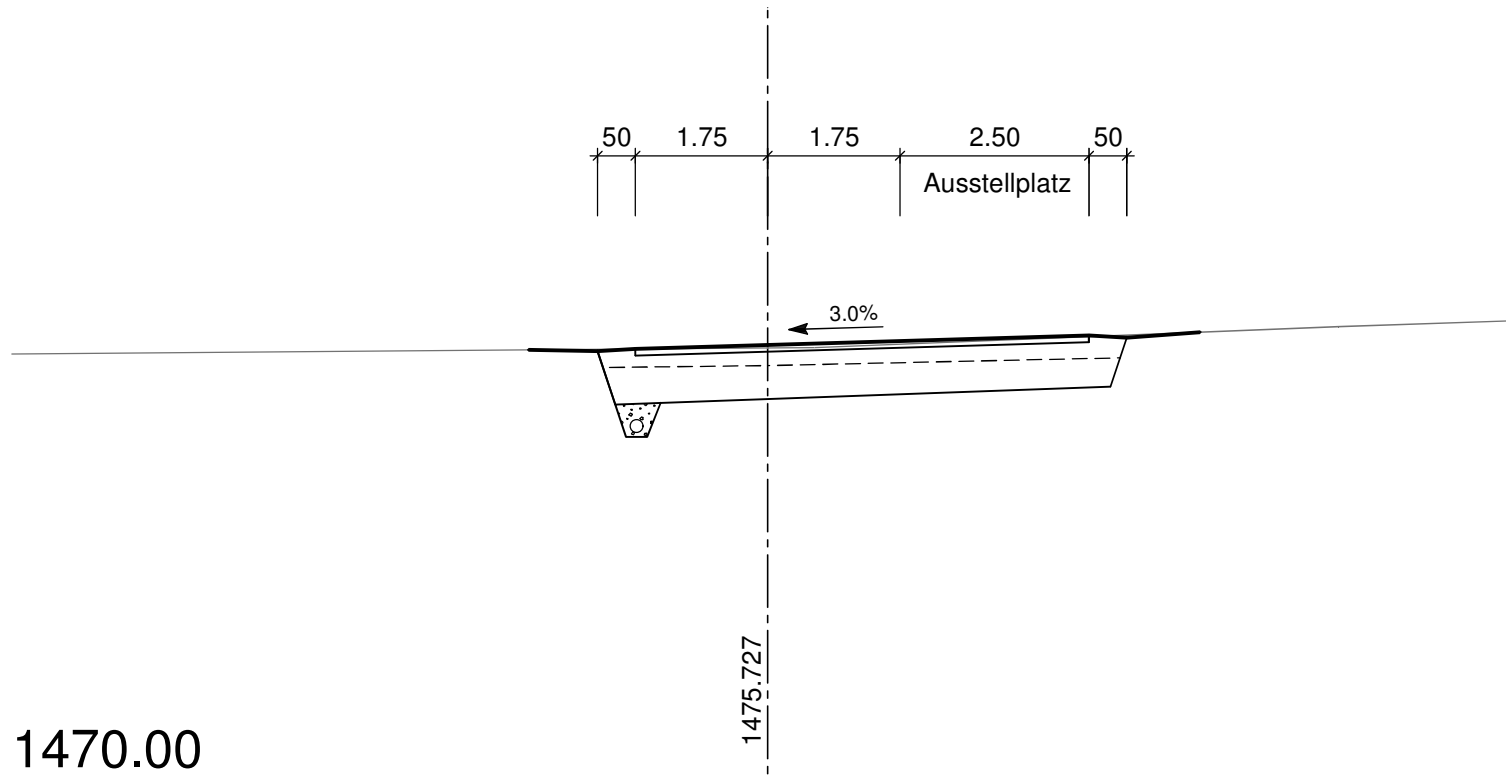

# STRASSE 1

150.00

P = 1478.44

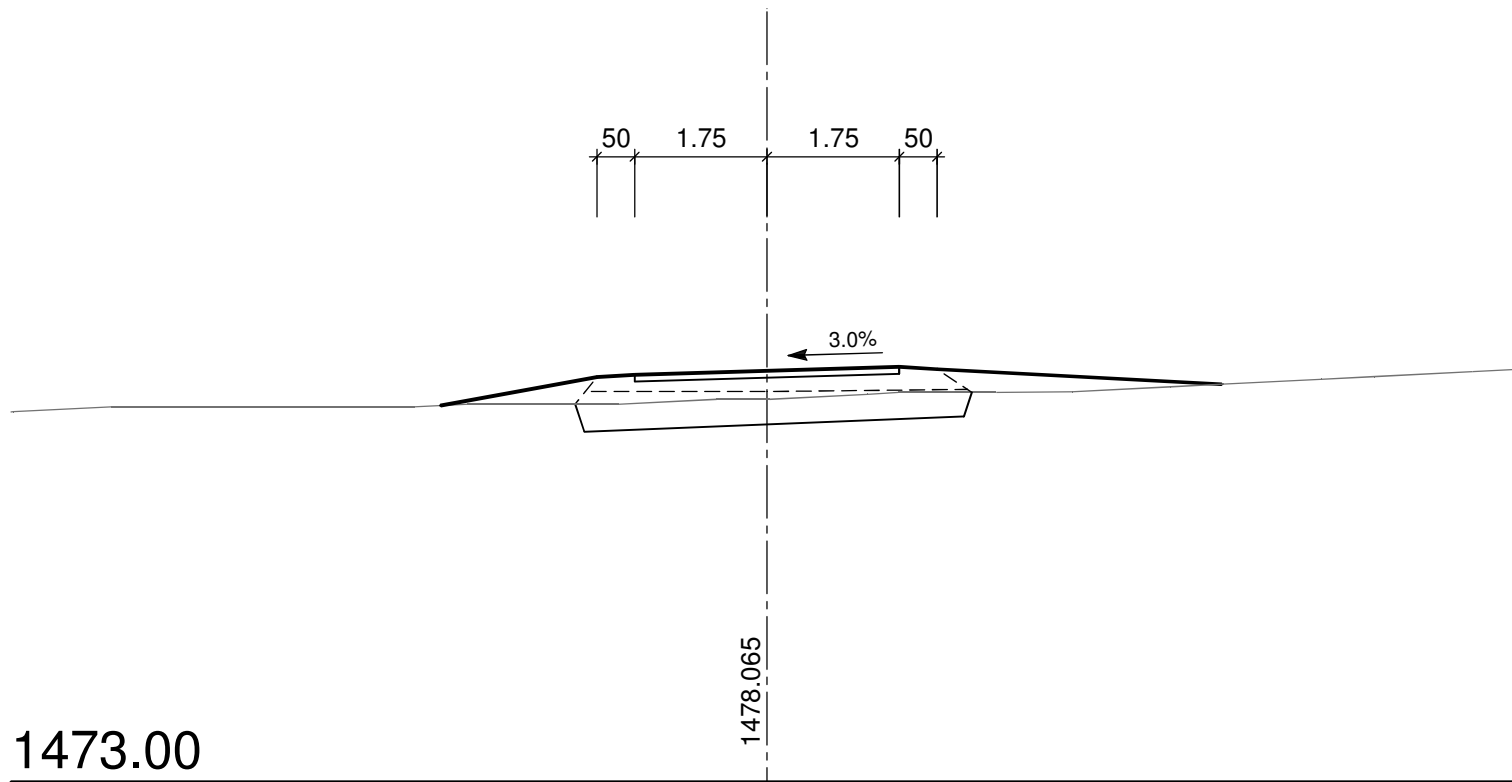

# STRASSE 1

160.00

P = 1478.31

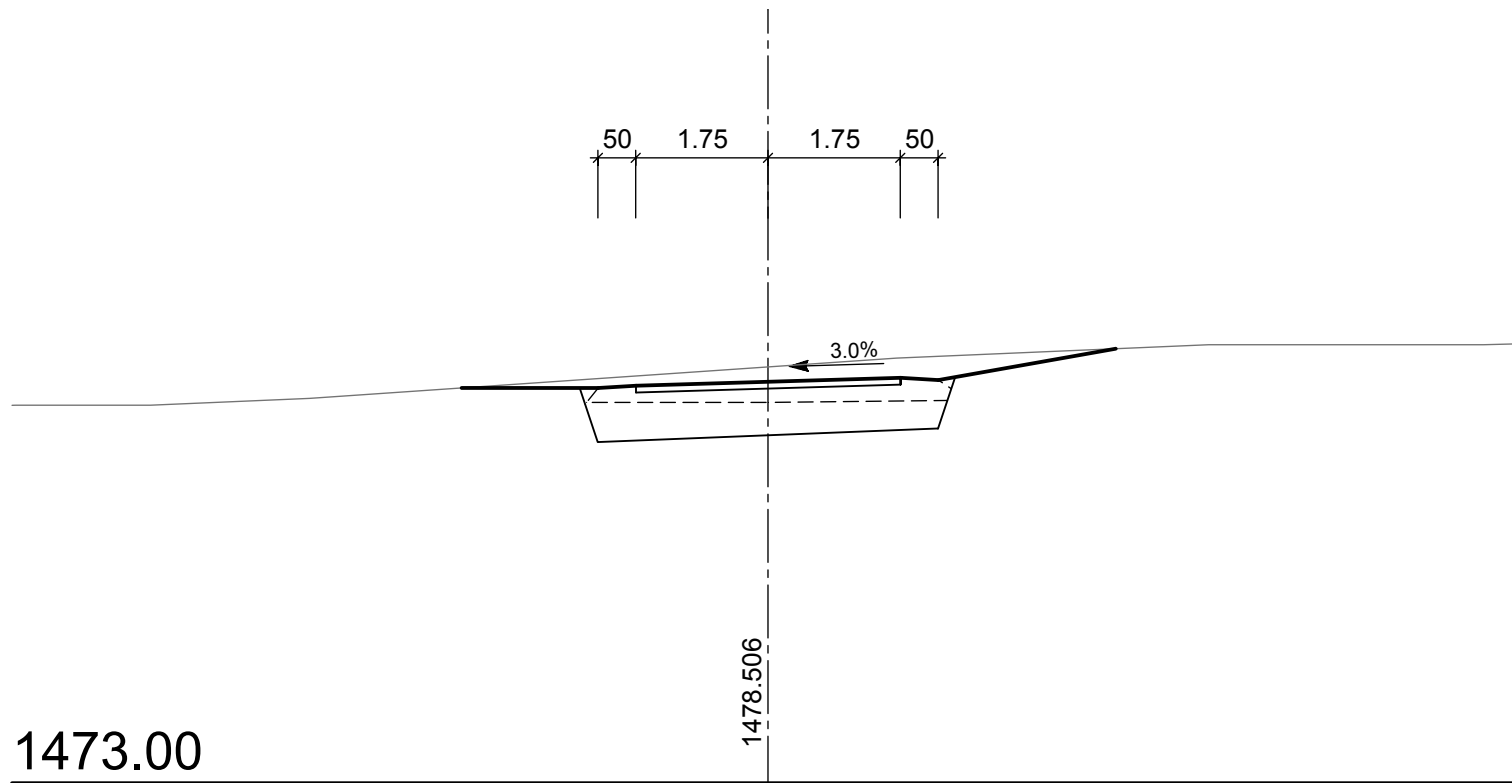

# STRASSE 1

210.000

P = 1477.56

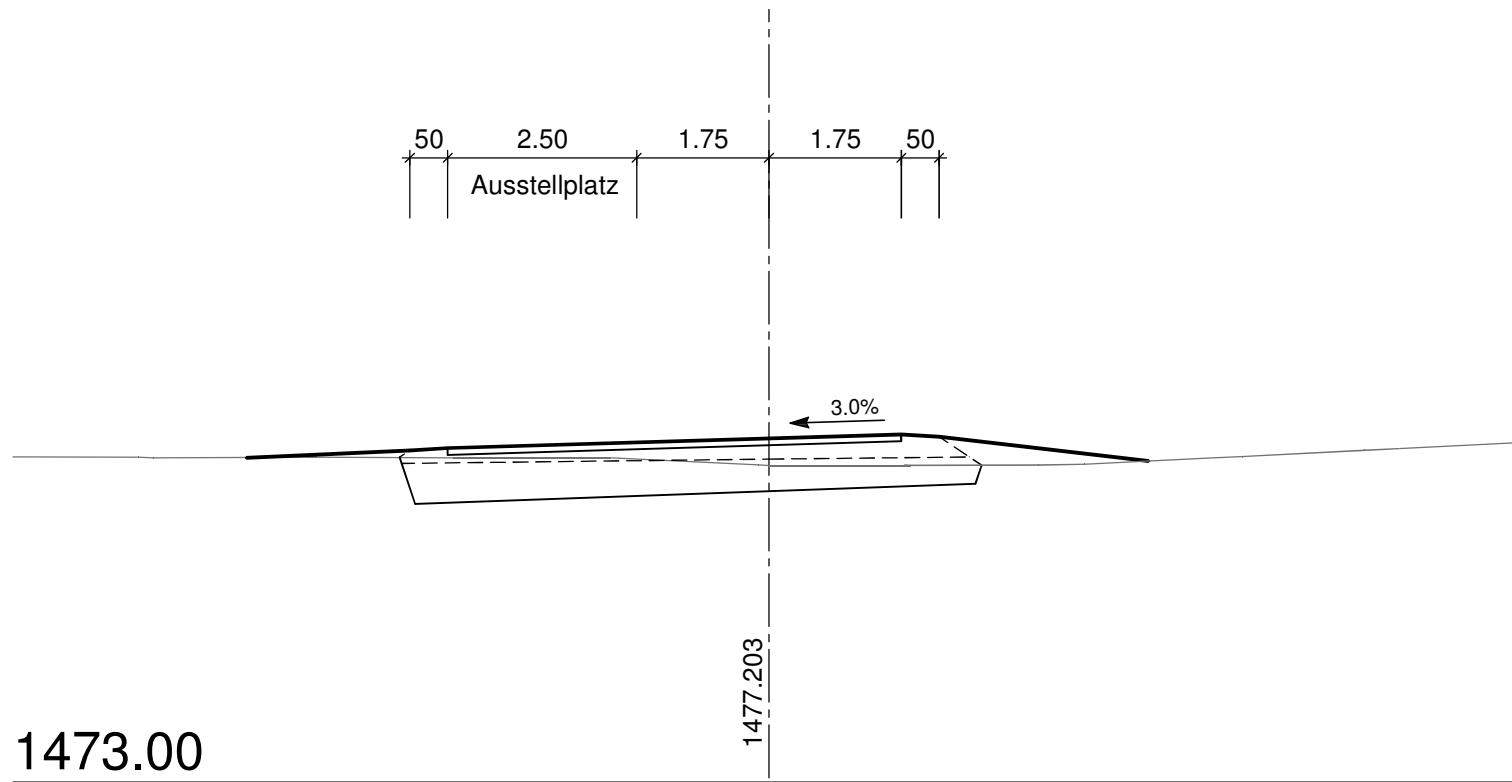

# STRASSE 1

250.000

P = 1477.25

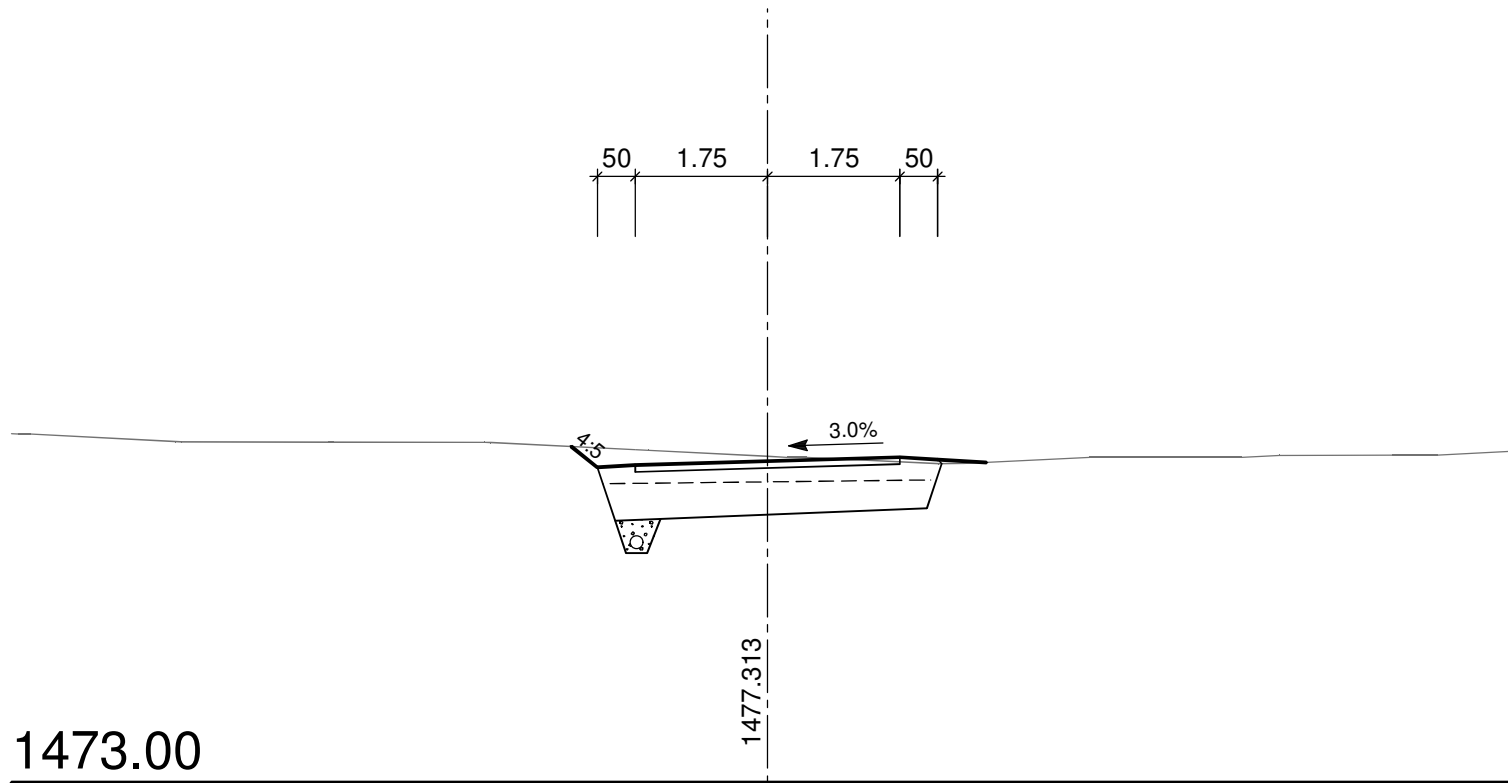

# STRASSE 2

40.000

P = 1476.161

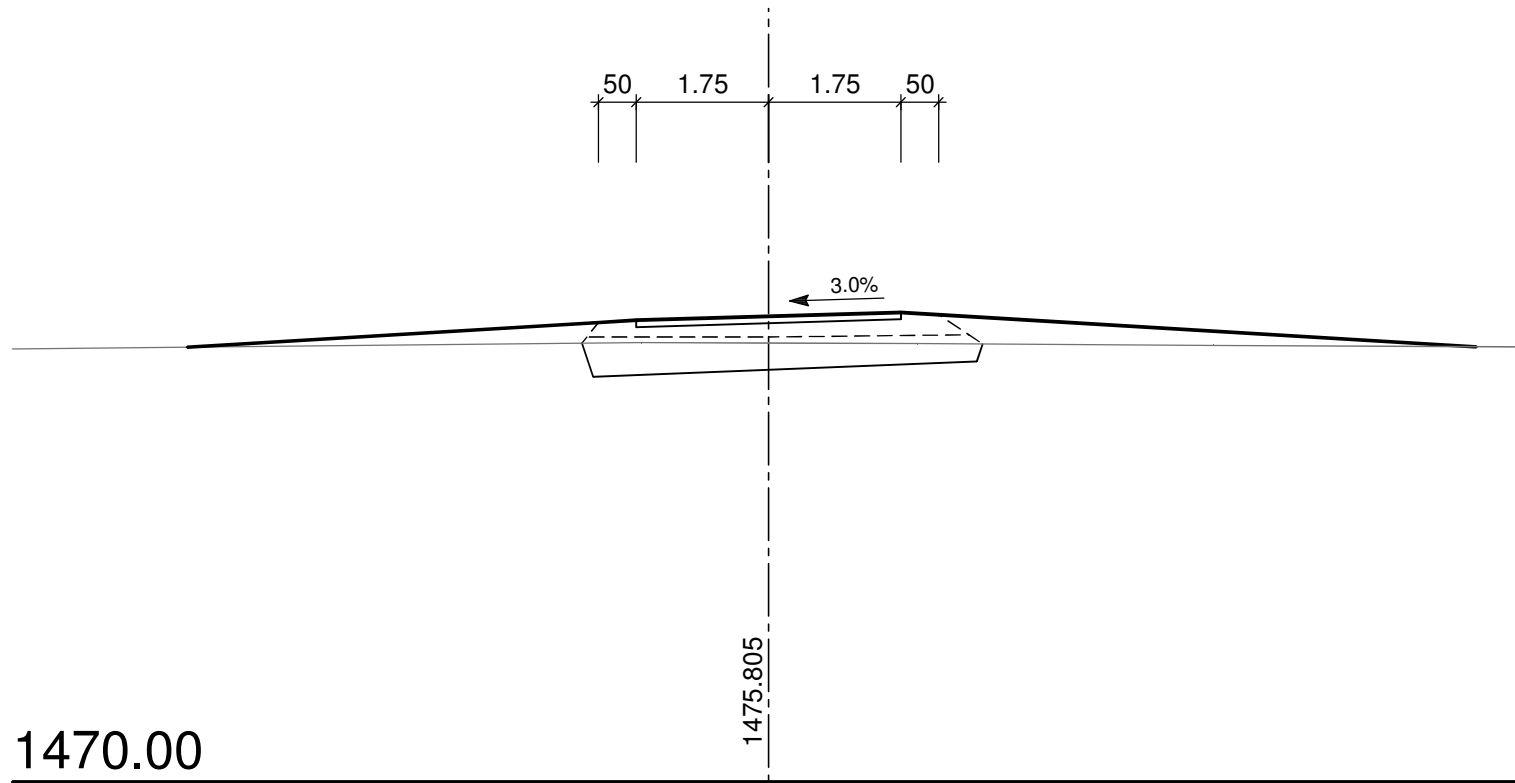



# STRASSE 2

70.000

P = 1476.090

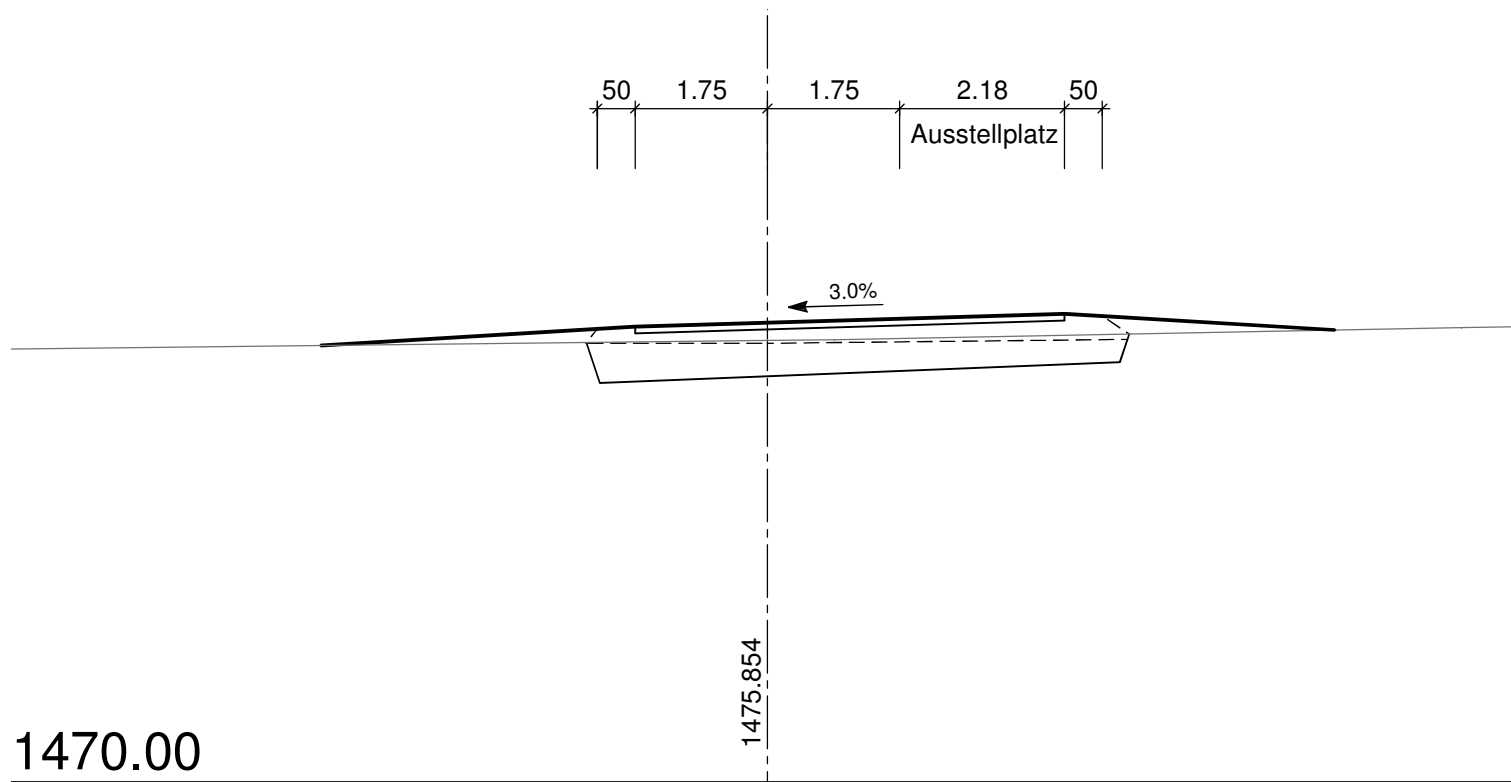

# STRASSE 3

30.000

P = 1476.567

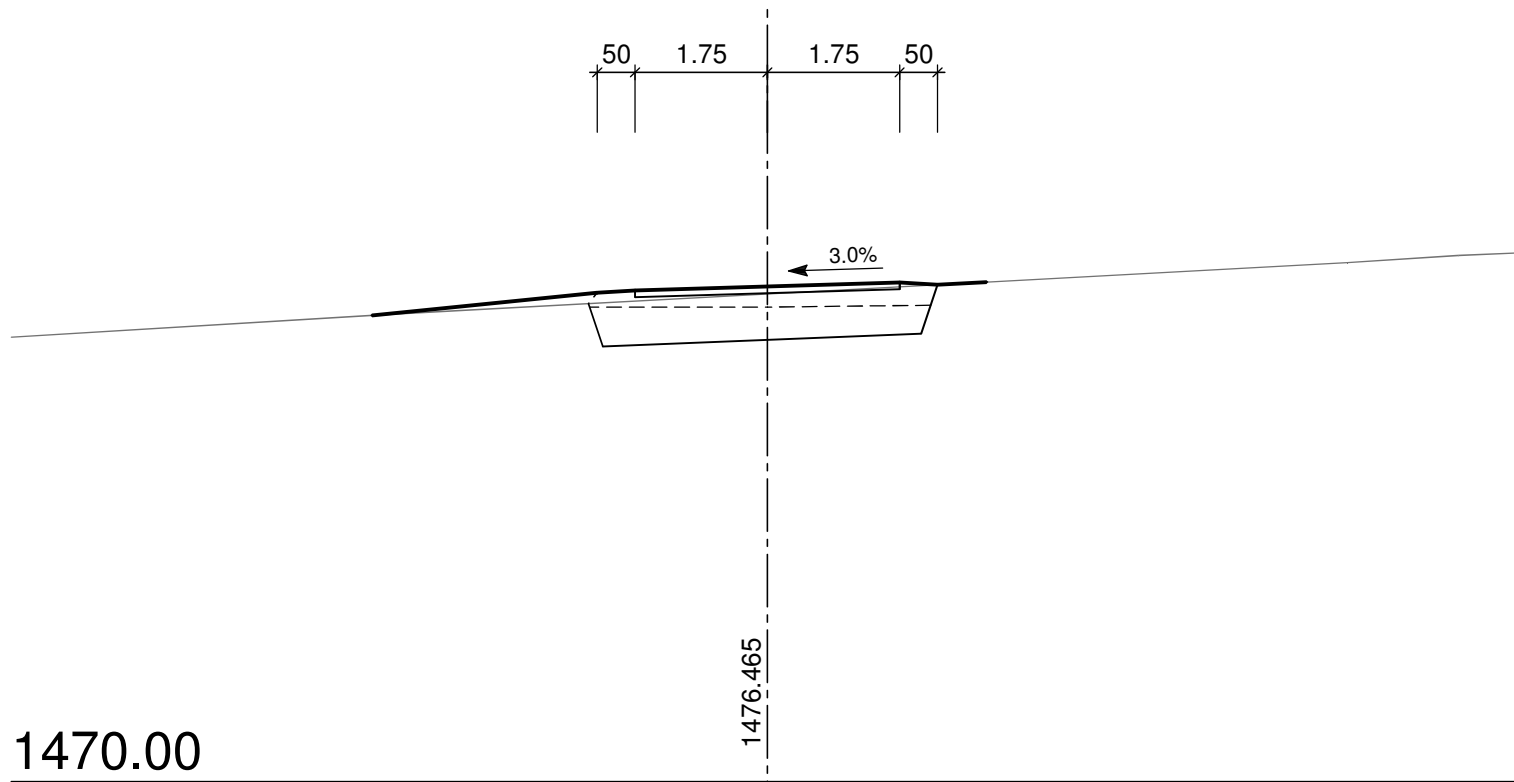

# STRASSE 3

70.000

P = 1477.469

